

Installation / Operation Manual

The ELIMINATR™ Water Treatment System

Signature Series Control Valve

For Model Numbers :

- MSI32**
- MSI48**
- MSI64**
- MSI96**



| General Specifications | | | | |
|--|----------------------------|----------------------------|----------------------------|-----------------------------|
| | MSI32 | MSI48 | MSI64 | MSI96 |
| Grains Capacity / Regeneration | 35,000 32,000 26,500 | 52,500 48,000 39,750 | 70,000 64,000 53,000 | 105,000 96,000 85,000 |
| Salt Used / Regeneration (pounds) | 15.0 10.0 6.0 | 22.5 15.0 9.0 | 30.0 20.0 12.0 | 45.0 25.0 18.0 |
| Maximum Raw Water Hardness (grains) | 75 | 100 | 100 | 100 |
| Maximum Clear Iron / Manganese (ppm) | 15 | 20 | 20 | 20 |
| Exchange Resin (cu. ft.) Garnet Sand Underbed | 1.0 15 lbs. | 1.5 15 lbs. | 2.0 35 lbs. | 3.0 35 lbs. |
| Mineral Tank (Vortech) | 9 x 48 | 10 x 54 | 12 x 52 | 14 x 65 |
| Brine Tank (polyethylene w/ grid & safety) | 18 x 33 | 18 x 33 | 18 x 33 | 18 x 40 |
| Service Flow Rate (gpm) * | 10.0 | 11.0 | 12.0 | 14.0 |
| Backwash Flow Rate (gpm) | 1.2 | 1.5 | 2.0 | 3.0 |
| Gallons Used / Regeneration | 59 | 68 | 102 | 135 |
| Space Required (D x W x H inches) | 18 x 27 x 56 | 18 x 28 x 62 | 18 x 30 x 60 | 18 x 32 x 74 |
| Approximate Shipping Weight (pounds) | 130 | 163 | 204 | 355 |

** The pressure drop does not exceed 15.0 psi at Service Flow Rate.*

PLEASE NOTE THESE SPECIFICATIONS BEFORE PROCEEDING

Operating Pressure Range : 20 - 125 PSI
Operating Temperature Range : 33° - 120° f
Inlet / Outlet Pipe Size : 3/4" FNPT

PLEASE COMPLY WITH ALL APPLICABLE PLUMBING CODES
PROTECT THE SOFTENER AND PIPING FROM FREEZING TEMPERATURES

Please read the entire Owner's Manual and Instructions before installation.
This Owner's Manual must stay with the unit.

How A Water Softener Works

Water hardness is derived from **Calcium** and **Magnesium** minerals that have been dissolved into water under the earth's surface. These minerals are found in limestone deposits and are the source of hard water. The amount of hardness in a given water supply is dependent upon the quantity of Calcium and Magnesium present and the length of time water has been in contact with them. This can vary dramatically from well-to-well and, for this reason, a water analysis is imperative in order to determine the proper treatment method. The degree of hardness increases as the concentration of Calcium and Magnesium "ions" increase and is measured in **Grains Per Gallon (gpg)**.

The problem of hard water in the home / business comes to light in many facets of daily use. Water spots and scum left behind on bathtubs, fixtures and showers; wear and tear on appliances; calcium build-up in hot water heaters and piping; and, greater amounts of soaps and detergents being used are just a few examples.

The modern water softener is designed to reduce ions and their unpleasant side effects. Special resin beads in the softener mineral tank are used to change hard water into soft water. The surfaces of these beads are covered with sodium ions. As hard water enters the mineral tank and comes into contact with the resin, an exchange of ions takes place as dissolved Calcium and Magnesium ions cling to the resin surface and sodium ions take their place, thus softening water. This process is called **Ion Exchange**. Over time, the sodium ions used for the exchange process become depleted and must be replenished.

The water softener provides a **Regeneration** process whereby brine solution enters the mineral tank, driving-off the collected hardness ions and replenishes the surface of the resin beads with more sodium ions. This process is automatically initiated by the control valve on the mineral tank. The regeneration process has four basic cycles as follows:

1. **Backwash** - The control valve directs the water flow in a reverse direction through the mineral tank, separating the resin beads and flushing any accumulated particles to a waste drain.
2. **Brine & Rinse** - In the first part of this cycle, the control valve directs brine solution downward through the mineral tank, driving-off collected hardness ions and replenishing the resin beads with sodium ions. The second part of the cycle rinses hardness ions and excess brine from the mineral tank to the waste drain.
3. **Rapid Rinse** - The control valve directs the water downward, settling and recompacting the resin bed.
4. **Brine Refill** - The control valve directs fresh water into the salt compartment to create new brine solution for the next scheduled regeneration.
5. **Service** - This is the normal "operating" cycle where hard water enters the mineral tank, comes into contact with the resin beads and exchanges hardness ions for sodium ions - the water then becomes "soft" and ready for use.

Pre-Installation Check List

A water test should always be performed in order to determine total water hardness (in gpg) and total dissolved iron (in parts per million - ppm). This is critical for proper equipment selection, sizing and for determining the program for regeneration frequency. If heavy concentrations of iron (above 5 ppm), iron coloration, iron bacteria or sediment are present, filtration prior to the softener will most generally be required. Certain states may require a licensed plumber for installation.

Note : Flexible water supply connectors and flexible drain line tubing may not be allowed in your locale. Please check with local plumbing code officials prior to installation.

Installation Requirements

- A level floor position ahead of piping into water heater.
- Unit must be installed at least 10 feet ahead of the inlet to a water heater to prevent damage due to back-up of hot water.
- DO NOT install the unit in an area of direct sunlight or where freezing temperatures may occur! (See Installation Diagrams for proper placement and plumbing connections.)

Major System Components :

1. **Brine Tank** - This tank holds the salt that is added to the softener. This salt is dissolved with water to form a brine solution used in the softener regeneration process.
2. **Resin Tank** - This tank contains the ion exchange resin media. Water flows through the resin tank under pressure to come into contact with the resin for water softening.
3. **Control Valve** - The valve directs water through the resin tank for water softening and controls the flow of water / brine for the regeneration process.

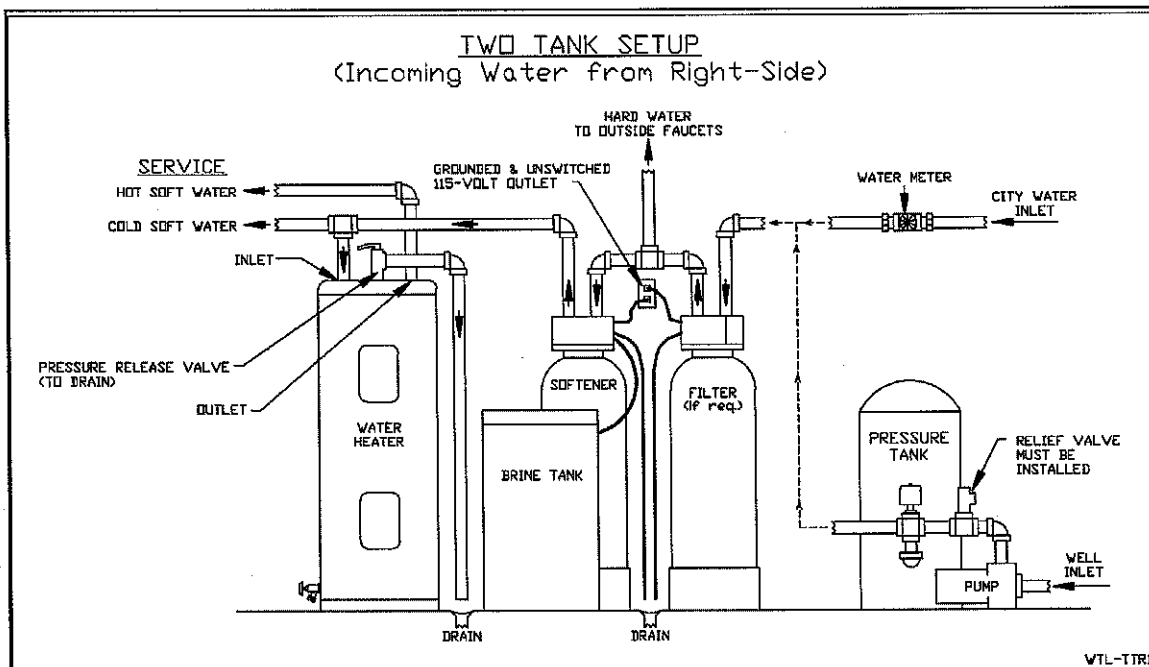
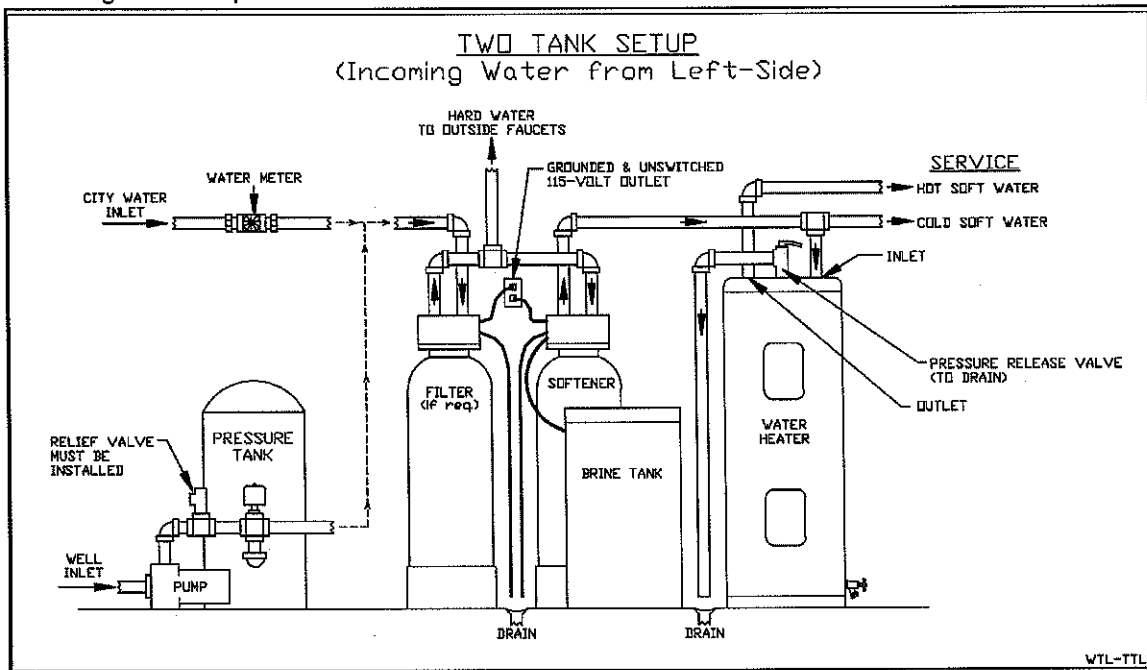

Softener Location / Other Requirements

- Locate the unit near an unswitched, 120 volt / 60 Hz grounded electrical outlet.
- Check for distance and proper drain installation (e.g. floor drain, washing machine standpipe).
- Determine type and size of piping required for softener connection (e.g. copper, galvanized, PVC plastic).

Note : If household plumbing is galvanized and you intend to make the installation with copper (or vice versa), obtain di-electric unions to prevent dissimilar metal corrosion.

Note : Where the drain line is elevated above the control valve or exceeds 20 feet in length to reach the drain, use 3/4" I.D. drain line tubing instead of 1/2" I.D. Drain line tubing is not included.

Caution : *If sweat soldering copper pipe (remember to always use lead free solder and flux), cover yoke and bypass valve with wet rags to prevent heat damage to connections and control valve! If using PVC or plastic pipe, primers and solvent cements specifically recommended for use with potable water are required.*

Note : All plumbing lines not requiring "soft" water should be connected "upstream" of the softener. (See Typical Installation Diagrams.)

Installation Procedure

- Water Supply Connections and Bypass Valve -

To allow for softener servicing, swimming pool filling or lawn sprinkling, a manual bypass valve has been installed at the factory. The bypass allows hard water to be manually routed around the softener.

1. Position softener at desired location for installation. (See Installation Diagrams.)
2. **For MSI96 Units only** - The resin material is shipped separately from the mineral tank. Remove the valve by unscrewing from center hole. Use a cork or tape to place over top of distributor tube to prevent material from entering tube while filling. Place funnel in hole. Pour several gallons of water in the tank. Garnet Sand underbedding is already installed. *Pour in the resin material on top of the Garnet Sand underbedding.* Remove funnel and cork or tape from distributor tube. Clean tank threads and fill the mineral tank completely with water. Replace the valve, being careful to position the distributor tube into the distributor tube pilot hole.
3. Turn OFF main water supply and OPEN nearest faucet to relieve pressure.
4. Cut main line and install appropriate elbows and extensions. Inlet and outlet connections on the control valve are 3/4" FNPT. (1" FNPT for MSI96.)

Note : An optional 1" FNPT yoke is available.

Caution : *Raised arrows located on the sides of control valve body and bypass valve indicate proper direction of water flow. Install inlet and outlet piping in direction of arrows.*

6. Rotate inlet and outlet knobs on bypass valve to the bypass position (position of bypass knobs are at right angles to inlet / outlet piping).
7. Turn the main supply line on to restore water service to the home.
8. OPEN nearest faucet to evacuate air and repressurize plumbing lines.
9. Check for leaks!

- Drain Line Connection -

1. Pull out clip and remove drain line assembly located on the left side of control valve. Remove drain line hose barb and wrap threads with Teflon tape. Reinstall drain line hose barb. **Caution :** *Hand tighten only!!* Replace drain line assembly and reinstall clip.
2. Install 1/2" I.D. drain line tubing (not included) from hose barb to an open drain. A 4" gap between the end of the drain line and the open drain is required to prevent waste water backflow. Keep the drain line as short as possible. An overhead drain line can be used if necessary, but should discharge below the control valve. A syphon trap (taped loop) at the outlet of the drain line is advisable to keep the drain line full and assure correct flow during regeneration. Elbows or other fittings must be kept at a bare minimum.

Note : Where the drain line is elevated above the control valve or exceeds 20 feet in length, 3/4" I.D. drain line tubing should be used.

- Brine Line and Overflow Connection -

1. Position brine tank on a smooth, level surface near the softener resin tank. If necessary, the brine tank can be placed at a higher level than the resin tank, but **never at a lower level**.
2. Install one end of 3/8" O.D. by 1/4 I.D. brine line tubing (included with unit) to compression fitting located on left side of control valve.
3. Remove brine tank cover.
4. Remove cap from brine well.
5. Insert opposite end of brine line through outer hole in brine tank.
6. Connect brine line to compression fitting on safety brine valve located inside brine well. Replace brine well cap.
7. Install 1/2" I.D. drain line tubing (not included) to the overflow fitting on brine tank located just below the brine line.
8. Run the opposite end of brine tank drain line to a suitable drain.
9. Install Res-Up™ feeder in brine tank per instructions.
10. Fill Res-Up™ feeder with liquid Res-Up™. Res-Up™ is available in quart and gallon bottles (not included).

Note : The brine tank drain line is gravity flow and must discharge below the overflow fitting.

Caution : Do not TEE to the main drain line from control valve.

Notice : The brine overflow is provided as a back-up in the event the safety float shut-off should fail, allowing the brine tank to overflow. This drain connection would then carry the excess water to the drain and prevent flooding of the floor. Therefore, no liability will or can be assumed by the manufacturer of the softener should this occur.

- Electrical Connection -

1. Connect the power supply to the control valve and plug into a 115 volt / 60 Hz receptacle.

- Installing Battery Back-Up -

1. Remove the rear cover.
2. Install a 9 volt battery. Refer to page 3, item 3 of the Signature Series Service Manual.
3. Reinstall rear cover.

- Pressurizing The System -

1. Make certain Signature Series Control Valve is in **SERVICE** position.
2. Slowly rotate inlet knob of the bypass valve to the **SERVICE** position. Slowly rotate outlet knob to the **SERVICE** position. (Position of bypass knobs are parallel to inlet / outlet piping.)
3. Open the nearest faucet to evacuate air from plumbing lines.
4. Check for leaks! If water is observed leaking from bottom of bypass knobs, close and open bypass knobs several times to seat o-rings.
5. After air is evacuated from plumbing lines, close inlet knob (position of bypass knob is perpendicular to direction of inlet pipe) on bypass valve.

- Programming The Control Valve -

Refer to page 2 of the Signature Series Service Manual for main menu programming and instruction.

1. Set time of day.
2. Set a.m. or p.m.
3. Set water hardness in grains per gallon (gpg).

Note : If the water contains iron and/or manganese, multiply the total parts per million (ppm) by "four" (4) and then add to the grains per gallon (gpg) of hardness. Use this COMPENSATED HARDNESS level when programming the regeneration frequency.

Refer to page 7 of the Signature Series Service Manual for master programming and instructions.

1. Set regeneration day override. (This is particularly useful when iron is being treated to prevent fouling of the resin.)
2. Set regeneration time, if other than 2:00 a.m. is desired.

Note : Salt settings are pre-set at the factory for the maximum shown on the capacity charts. If an economy salt setting is desired, refer to page 8, item 4 in the Signature Series Service Manual.

Warning : Do not reduce salt setting below 9 lbs. as the water level in the brine tank will not reach the grid plate.

- Control Valve Operation -

Refer to page 4, item 2 of the Signature Series Service Manual Instructions.

1. Advance **control valve** to **BACKWASH** (cycle 1) position and allow water to run to the drain for 3 to 4 minutes.
Warning : Close **inlet** valve on bypass prior to selecting the backwash position. After backwash position has been established, **slightly** open inlet valve on bypass to evacuate air from the media tank. Fully open inlet valve when all air is depleted. This procedure will prevent media from being uplifted into control valve.
2. Advance **control valve** to **BRINE REFILL** (cycle 4) position and allow the brine tank to fill just over the salt grid plate.
3. Advance **control valve** to **BRINE & RINSE** (cycle 2) and allow the control valve to draw water from the brine tank until it stops. If no draw is observed, check tightness of brine line compression fittings.
4. Advance **control valve** to **RAPID RINSE** (cycle 3) position and let water run to drain for 3 - 4 minutes.
5. Advance **control valve** to **BRINE TANK REFILL** (cycle 4) position and allow the control valve to automatically fill the brine tank.

Note : Control valve will advance to service position automatically.

Start Up Procedure

- Disinfection -

The material used in the construction of the modern water softener will not support the growth of bacteria. However, the conditions existing during shipment, storage and installation are unknown and thus dictates the disinfecting of a softener after installation, before it is used to treat potable water. With this in mind, your newly installed water softener should be disinfected using the recommended procedure described in this section. Ordinary laundry bleach is an excellent disinfecting agent for this purpose. The proper dosage for your particular softener model is listed below.

Figure 5

| Unit Capacity | Cubic Feet of Resin | Chlorine Dosage |
|---------------|---------------------|-----------------|
| 35,000 | 1.00 | 1.2 ounces |
| 52,500 | 1.50 | 1.8 ounces |
| 70,000 | 2.00 | 2.4 ounces |
| 105,000 | 3.00 | 3.6 ounces |

1. Measure the proper amount of chlorine bleach as shown above.
2. Pour the chlorine directly into brine well located inside brine tank.
3. Replace brine well cap.

- Filling The Brine Tank With Salt -

To expect a high level of performance and reliability, a salt manufactured specifically for water softeners must be used. Salt of this grade is virtually free from dirt and other particulate that would eventually cause the softener to malfunction. A pellet type salt is recommended, although any high quality water softener salt (such as solar salt) will suffice. The salt level will decrease after each regeneration cycle. Consequently, the salt compartment will need to be checked and replenished periodically.

1. Fill the brine tank with water softener salt as described above. This will be approximately 250 pounds of salt.

Warning : Do not fill salt above level of the brine well.

2. Replace brine tank lid.

- Final Check -

1. Be certain the bypass valve is in the **SERVICE** position.
2. Make sure the power supply is connected to an uninterrupted 115 volt outlet.
3. Check that the time of day is set.
4. Double check regeneration schedule.
5. Make final check for leaks!
6. Fill out and mail warranty card.
7. Leave all manuals with unit.

Operation, Care and Cleaning

When the inlet / outlet knobs on the bypass valve are in the **SERVICE** position (position of bypass knobs are parallel to the inlet / outlet piping), water is directed through the water softener. Water may be bypassed by turning the inlet / outlet knobs to the bypass position (position of bypass knobs are at right angles to inlet / outlet piping). Water to the home will bypass the softener and be *untreated*.

You should manually bypass the softener if :

1. The outside lines do not bypass the water softener and water is to be used for lawn sprinkling or other similar uses.
2. Servicing the water softener.
3. A water leak from the water softener is evident.
4. *Shock treating* water well and piping with chlorine or other disinfectant.

- Extra Regeneration -

If soft water demands are unusually heavy, an extra regeneration can be initiated manually :

Refer to page 4, item 2 of the Signature Series Service Manual.

- To Skip A Regeneration -

1. For vacations or extended periods of absence, the power supply can be disconnected from the control valve.
2. Upon return, plug in cord and reset the time of day, if 9 volt battery was not installed. If battery was installed, replace battery.

- General Care and Cleaning -

1. Do not place heavy or sharp objects on water softener.
2. Use only mild soap and warm water to clean exterior of the unit. Never use harsh, abrasive cleaners.
3. Protect the water softener and drain line from freezing.
4. Reset time for daylight saving time periods.
5. Replace 9 volt battery once a year.
6. Inspect and clean the brine tank when sediment appears in the bottom of the salt compartment.
7. Always keep the brine tank supplied with good quality salt, a type designed for use in water softeners.

Res-Up Feeder Installation Instructions

1. Remove top cover, fill the Res-Up Feeder® (plastic container) to top with water so that tube and wick are wetted. Allow to soak for 15 minutes or more.
2. Empty water and pull tube and wick through feeder until stone is upright, but still resting in bottom of stone well. The outlet end tube and wick must be below the bottom level of Res-Up Feeder.
3. Drill two 1/8" holes in brine tank as shown in figure 2.
4. Punch (or drill) a 5/8" hole in the brine well cap as shown in figure 3.
5. Clip mounting bracket over feeder with **hooks** pointed up. Insert end of tube in the brine well cap and mounting bracket, rotating feeder downward into position as shown in figure 1.
6. Fill feeder with Res-Up® Cleaner to *fill line* on label.
7. Replace cover on feeder and automatic feeding will occur within a few hours.
8. Make sure the knotted wick end is in the bottom of the stone well.

Figure 1.

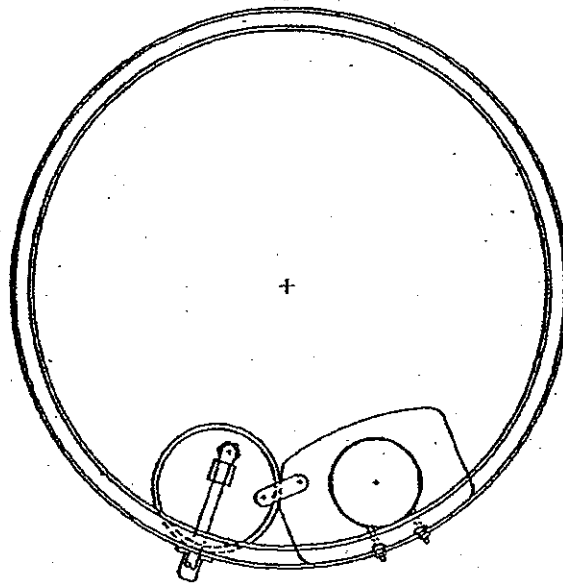

Figure 2.

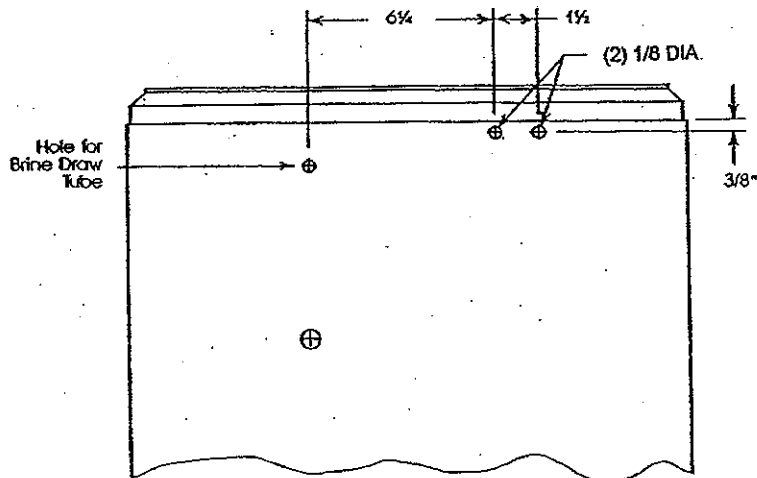
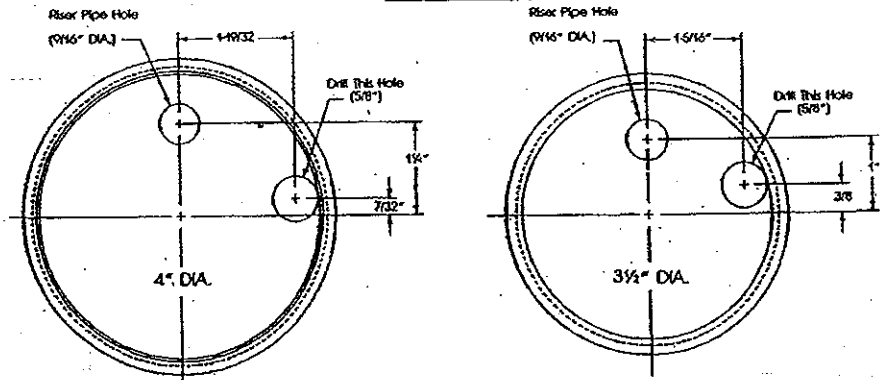
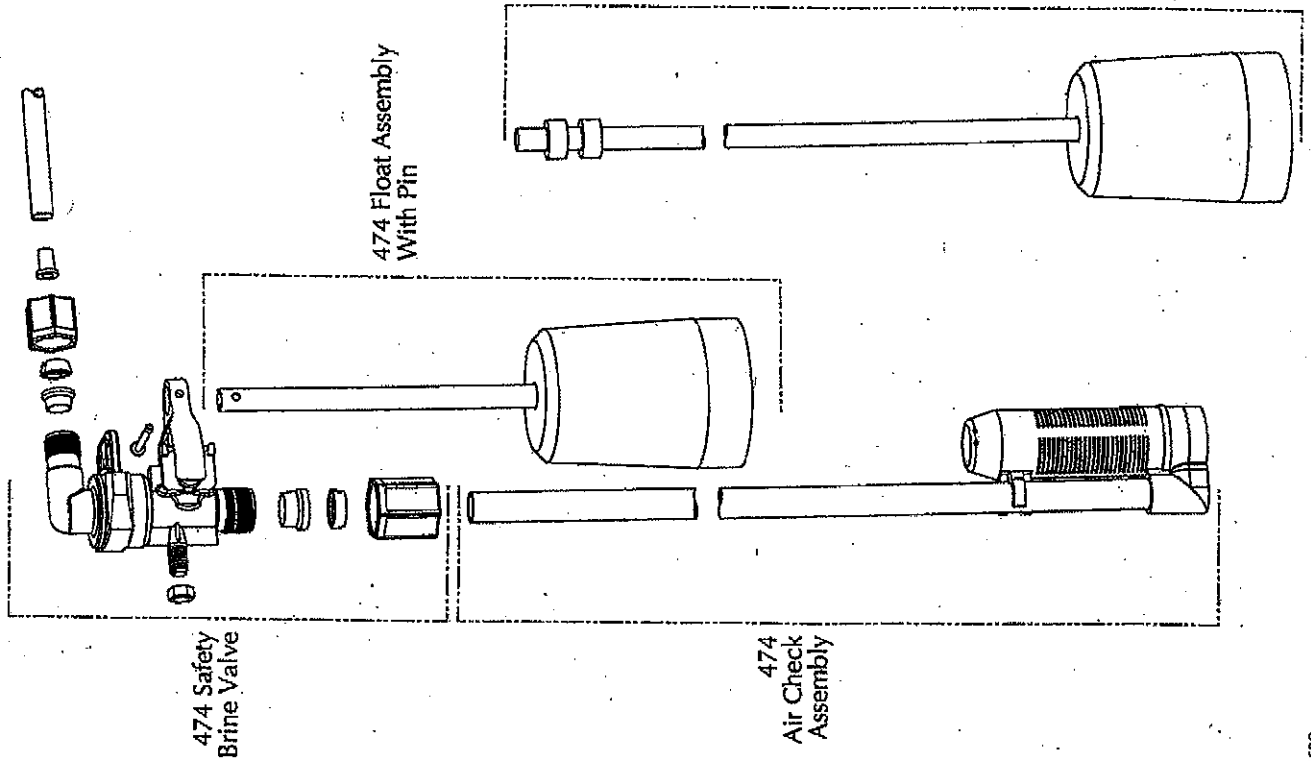

Figure 3.



Assembly Guide For 474 Safety Brine Valve System



**If GFN Nut Assembly
is unassembled,
follow these steps**

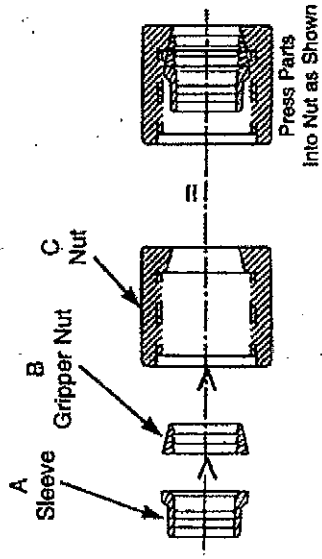



10 - 5 - 3 - 1

"LIMITED" WARRANTY

Water Treatment Equipment

During the time periods and subject to the conditions hereinafter set forth, CSI Water Treatment, will repair or replace to the original user or consumer, any portion of your new CSI Water Treatment product which proves defective due to defective materials or workmanship of CSI Water Treatment. Contact your nearest authorized CSI Water Treatment dealer for warranty service. At all times CSI Water Treatment shall have and possess the sole right and option to determine whether to repair or replace defective equipment, parts, or components. Damage due to conditions beyond the control of CSI Water Treatment is **NOT COVERED BY THIS WARRANTY.** (Contact parcel or freight company for claims on freight damage in transit.)

WARRANTY PERIODS :

| ITEM | *10 YRS | *5 YRS | *3 YRS | *1 YRS |
|---------------------------|------------|-----------|-----------|-----------|
| Residential Mineral Tanks | ● | | | |
| Commercial Mineral Tanks | | ● | | |
| Softener/Filter Control | | ● | | |
| Brine Tank Assemblies | | | ● | |

| ITEM | *5 YRS | *3 YRS | *1 YRS |
|---------------------------|-----------|-----------|-----------|
| Reverse Osmosis System | ● | | |
| Other Accessories & Parts | | | ● |

* From Date of Installation

LABOR, ETC., COSTS : CSI Water Treatment shall **IN NO EVENT** be responsible or liable for the cost of field labor or other charges incurred by any customer removing and/or reaffixing any CSI Water Treatment product, part or component thereof.

THIS WARRANTY WILL NOT APPLY : (a) To defects or malfunctions resulting from failure to properly install, operate or maintain the unit in accordance with printed instructions provided; (b) to failures resulting from abuse, accident or negligence; (c) to normal maintenance services and parts used in connection with such service; (d) to units which are not installed in accordance with applicable local codes, ordinances and good trade practices; (e) if the unit is moved from its original installation location; (f) unit is used for purposes other than for what it was designed and manufactured, and (g) filter media and exchange resins.

RETURN OF REPLACED COMPONENTS : Any item to be replaced under this Warranty must be returned to CSI Water Treatment in Ashland, Ohio, or such other place as CSI Water Treatment may designate, freight prepaid.

PRODUCT IMPROVEMENTS : CSI Water Treatment reserves the right to change or improve its products or any portions thereof without being obliged to provide such change or improvement of units sold and/or shipped prior to such change or improvement.

WARRANTY EXCLUSIONS : As to any specific CSI Water Treatment product, after the expiration of the time period of the warranty applicable thereto as set forth under the heading "Warranty Periods" above, **THERE WILL BE NO WARRANTIES, INCLUDING ANY IMPLIED WARRANTIES OF MERCHANTABILITY OR FITNESS FOR ANY PARTICULAR PURPOSE.**

Some states do not allow limitations on how long an implied warranty lasts, so the above limitation may not apply to you. No warranties or representations at any time made by any representative of CSI Water Treatment shall vary or expand the provisions hereof.

LIABILITY LIMITATION : IN NO EVENT SHALL CSI WATER TREATMENT BE LIABLE OR RESPONSIBLE FOR CONSEQUENTIAL, INCIDENTAL OR SPECIAL DAMAGES RESULTING FROM OR RELATED IN ANY MANNER TO ANY CSI WATER TREATMENT PRODUCT OR PARTS THEREOF.

Some states do not allow the exclusion of limitation of incidental or consequential damages, so the above limitation or exclusion may not apply to you.

The Warranty gives you specific legal rights and you may also have other rights which vary from state to state.

For your warranty protection (Magnason-Moss Warranty Act) the warranty card must be completed and returned to CSI Water Treatment within ten (10) days of installation. In the absence or other suitable proof of installation date, the effective date of this warranty will be based upon the date of manufacture plus thirty (30) days.

Direct all notices, etc. To : Service Department, CSI Water Treatment, 710 Orange Street, Ashland, Ohio 44805

Date : December, 2007